

## **Parallel Binding Process of Alternators with Arduino**

**Elif Merve BAHAR**

Manisa Celal Bayar Üniversitesi

**Kivanc BASARAN**

Manisa Celal Bayar Üniversitesi

**Isa Serdar TOPBAS**

Manisa Celal Bayar Üniversitesi

**Abstract:** In this study, the conditions for parallel binding of the alternators used in the power plants to grid were examined and the fulfillment of these conditions was carried out with Arduino. The power plant drive system has been modeled as Asynchronous motor module with 3 phase power of 5 kW. In the alternator part, asynchronous machine was used at 13 kVA power. Voltage, frequency, phase sequence and phase difference magnitudes of alternator and grid are used as input data of Arduino. Voltage, frequency, phase sequence and phase difference magnitudes of alternator and network are used as input data of Arduino. Four different modules have been designed to be integrated into Arduino for every magnitude. These modules evaluate the information from the grid and the alternator. Arduino brings the alternator and the grid in parallel via the relay at the output when appropriate conditions met. Modules designed for the training set, software embedded in Arduino allows practical parallel connection without using different measuring instruments.

**Keywords:** Power plants, Alternator, Grid, Training set

### **Introduction**

The world population is increasing day by day and the energy demand of this population is increasing in parallel. Energy need of mankind is met in various forms like electric and mechanical energy. Nowadays, relatively electric energy is quite important due to ecological effects of its generation.

Source of the energy is as important as the energy generated itself. Electric energy is generated from many sources such as the sun, wind, stream or fossil fuel. In addition to the quality of the energy source, in order to produce the energy efficiently, it is also important how clean and renewable the energy source is.

The energy obtained from fossil fuels and similar sources is no longer preferred. The main reason is that fuel emissions cause permanent damage to the environment. Global warming, acid rain, photochemical fog, etc. have many effects that threaten the future of mankind.

States acquire the energy they need from renewable energy generating plants. Electricity generated in the power plant is transferred to the grid. The network is a distribution line that allows the electricity to be used for various needs. Distribution is made through the cables extending from the plant to the houses.

In order to be able to connect to the grid from the alternators, it is necessary to meet certain conditions which are explained in Chapter 3 in details. Therefore, it must be checked whether the conditions are fulfilled. When the necessary conditions are met, a parallel connection to the network is provided via the output relay. In our work, the necessary conditions to parallel connect the alternators used in the power plants to grid were examined. An Arduino Microcontroller connected to the system is used for the control of those necessary conditions.

In this study, it is assumed that the electricity generated by the motor is produced from the fluids such as wind, stream, under natural conditions, as mentioned above. However, the test setup is driven by electricity from the network of the laboratory. As a drive mechanism, an asynchronous motor was used at a 3-phase 5kW power to simulate natural plant conditions. In the Alternator part, an asynchronous machine was used at 13 kVA power. Voltage, frequency, phase sequence and phase magnitudes of the grid are read from the modules designed for training in our laboratories. The readings were recorded as data input from the analog and digital ports of the Arduino. System requirements have been evaluated with software embedded in Arduino. When appropriate conditions are met, Arduino brings the alternator and the grid to the parallel connection position via the relay at the system output.

The advantages of this system are;

- Different measuring instruments are not used,
- Does not cause confusion,
- The parallel connection process is carried out practically without the need for an operator.

### **Parallel Binding To The Grid**

In order for electricity to be available, it must be distributed via the grid after it has been produced. Electricity generated in the plant is distributed by connecting the alternator to the network. The reasons why parallel connection required can be listed as follows ( Colak, 2003 and Chapman, 1987);

- The loads of power generating plants are not always the same. When the load increases, the alternator by being connected parallel to the grid is taken on the task of sharing the increasing load. For this reason, plants usually have more than one alternator.
- Since alternators do not always work with "nominal load", the efficiency is reduced. Therefore, instead of a large alternator that can accommodate the plant's most power, the use of a couple of small size alternators increase the efficiency.
- It is important that more than one alternator should be connected in parallel for system safety. While the system is running, even if an alternator breaks down, the others can continue to supply power to the system.
- It will be convenient to have more than one alternator during the maintenance of the alternator system. Even if one alternator needs to be switched off, the system will continue to feed as long as the others remain active.

The fluctuations in current and voltage may occur in the parallel bonding process. Therefore, bonding process has to take place after a series of control mechanisms. As mentioned in the previous sections, a few conditions have to be fulfilled.

The necessary conditions can be listed as follows.

1. The voltages of the alternators to be connected in parallel must be equal.
2. The frequencies of the alternators to be connected in parallel must be equal.
3. The phase sequences of the alternators to be connected in parallel must be the same.
4. Synchronization between alternators should be ensured and then parallel connection should be accomplished.

Previous studies have shown that these four conditions are controlled and then the synchronizations of the alternators are made using microcontroller based methods (Phadke,1994, Radovanovi, 2001, Mahmoud, 2003 and Metwally, 2000). As is often the case in this work, systems are installed with digital displays due to ease and high performance (Martin, 1993). A standard has been introduced including these steps since there is no other way to do the process (IEEE, 2005 and Çolak, 1999).

Figure 1 shows the parallel connection diagram of the alternators. In this diagram, the R, S and T letters represent 3 separate phases and M for the motors that drive alternators G1 and G2.

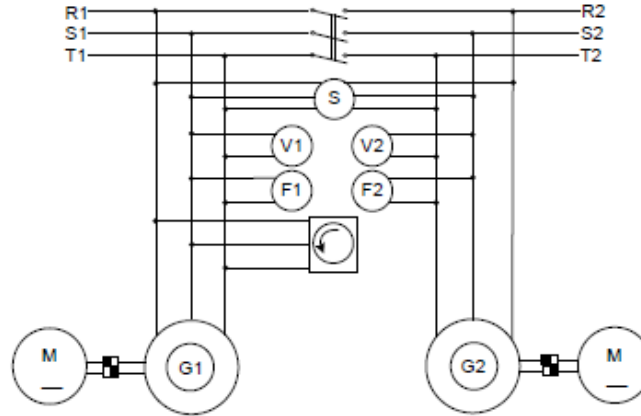

Figure 1. Parallel connection of alternators

### Parallel Connection of Alternators via Arduino

In the plants, the parallel connection is usually controlled by using analogue measurement instruments and classical methods by the operator. In this study, the Arduino Microcontroller system was used to make the parallel connection process independent of the operator, more practical and faster. Analogue and digital equipment used to collect measurements in the Arduino is shown in Figure 2. The voltmeter, the frequency meter, the phase-sequence indicator and the synchronizer are connected to the output of the alternator. Arduino reads the data from its digital and analogue ports, interprets and sends signal to relay when the parallel connection conditions are provided. After this, the feeding operation takes place via alternators connected in parallel to the grid.

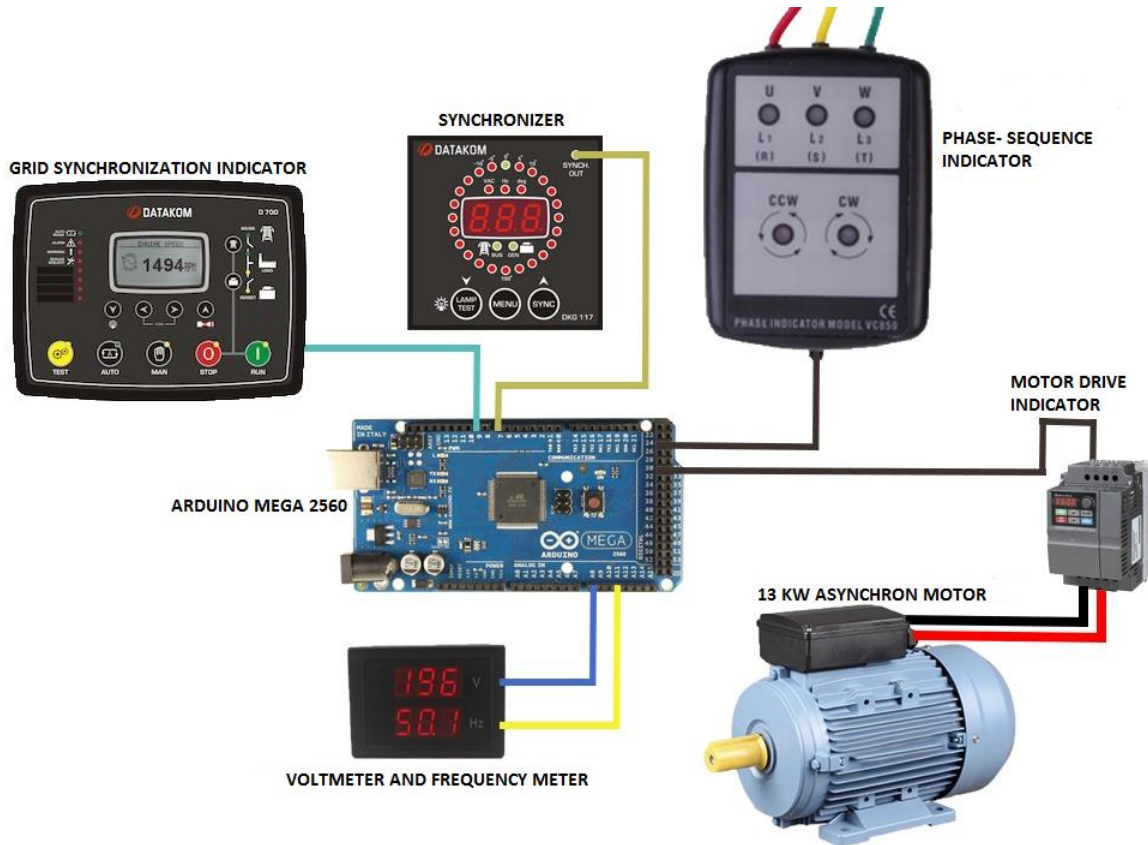

Figure 2. Arduino system

The equilibrium of voltages, which is the first condition of the connection, is measured with a voltmeter. According to the measured value, excitation currents equality is obtained by setting the alternator.

The equilibrium of frequency, which is the second condition of the connection, is measured with a frequencymeter. By setting the number of revolutions per minute of the systems that rotate the alternators, equality is provided in the frequencies they produce. The identity of phase sequences, which is the third condition of the connection, is measured with a phase sequences indicator. This indicator measures the direction of the rotating field.

Determination of the moment of synchronization, which is the fourth condition of the connection, is measured with one or three-phase synchroscope. In this study, the determination of the synchronization moment is performed by a phase synchronous motor. Determination of the moment is a very important point and requires great attention.

Arduino controls each of these conditions respectively. Figure 2 shows the analog and digital connections to Arduino from the measurement instruments. Figure 2 also shows the digital connection from the Arduino to the asynchronous motor. Figure 3 shows the flow diagram of the program embedded in Arduino.

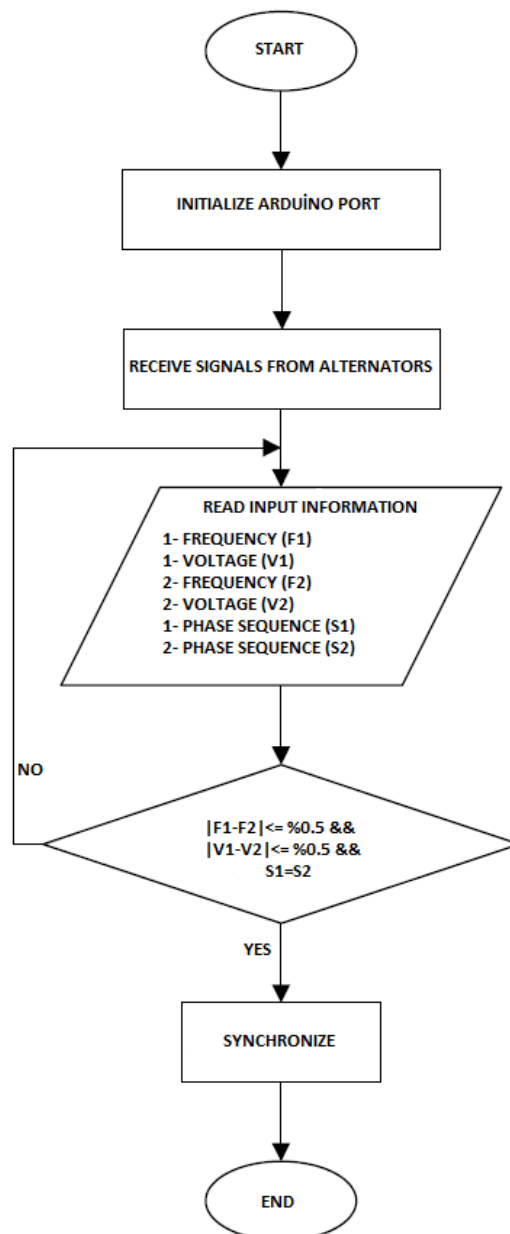

Figure 3. Flow diagram of the program embedded in Arduino

Arduino calculates the frequency and voltage values of the alternator according to the signals. Then, it makes a comparison. The difference between the frequency and the voltage should be equal to 0.5% or less. When this

condition is satisfied, Arduino commands "synchronize". The transistor, which is the switching element that controls the relay at the system output, provides parallel connections by sending digital signals. In addition, since the frequency and voltage amplitudes in the alternator can not be the same every time, these values are measured several times at different times during parallel connection. It has been seen that magnetic fields arising from asynchronous motors and alternators do not affect arduino and measurement system. However, alternators and motors are positioned as far away as possible in order not to damage arduino and digital measuring instruments.

## Results

In the current study, the parallel connection of the alternators to each other and to the grid was carried out numerically. Conventional parallel connection system and its principles, then microcontroller based Arduino control was described. It has been shown that the work done is much more controlled, safe and fast than the classical system. The difficulty of using the measurement instruments used in the classical method has been removed.

Arduino and measurement systems have been designed to require at least electronic equipment according to the conventional system. In addition, additional protective circuits are not needed because of the protective elements in the Arduino.

Due to the command loop speed of the Arduino, parallel connection conditions are sensitively checked many times. This study is important to future work on alternators and power electronic systems. This control system is also an example for the training of staff and students interested in the subject.

## References

- Colak, I. (2003). Synchronous Machines. *Seçkin Publishing*, Ankara.
- Chapman, S.J. (1987). Electric Machinery Fundamentals. *McGraw-Hill Book Company*.
- Çolak, I., Yılmaz, E.N. (1999). Simulation of the parallel connection of electrical power stations. *IJEEE International Journal of Electrical Engineering Education*, 36 (4), 332-341.
- IEEE Std. (2005). IEEE Power Engineering Society. *IEEE standard for synchrophasors for power systems*, C37. 118.
- Mahmoud, M. S., Ismail, A. (2003). Control of electric power systems. *Systems Analysis Modeling Simulation*, 43(12), 1639-1673.
- Martin, K.E. (1993). Precise timing in electric power systems. *IEEE International Frequency Control Symposium*, 15-22.
- Metwally, H.M.B. (2000). Operation of new variable speed constant voltage and frequency generator connected to the grid. *Energy Conversion and Management*, 41(7), 701-712.
- Phadke AG and subcommittee of the IEEE Power System Relaying Committee, Synchronized sampling and phasor measurements for relaying and control, *IEEE Transactions on Power Delivery*, 9 (1), 442- 452, 1994.
- Radovanovic, A. (2001). Using the internet in networking of synchronized phasor measurement units. *Elsevier, Electrical Power and Energy Systems* 23, 245-250.

---

### Author Information

---

#### Elif Merve Bahar

Manisa Celal Bayar University  
Acarlar Ave. Şehit Ali Karakuzu St. No:10 Turgutlu,  
Manisa / Turkey  
Contact E-mail: [elif.kalyoncu@cbu.edu.tr](mailto:elif.kalyoncu@cbu.edu.tr)

#### Kivanc Basaran

Manisa Celal Bayar University  
Acarlar Ave. Şehit Ali Karakuzu St. No:10 Turgutlu,  
Manisa / Turkey

#### Isa Serdar Topbas

Manisa Celal Bayar University  
Acarlar Ave. Şehit Ali Karakuzu St. No:10 Turgutlu,  
Manisa / Turkey

---